

## PERFORMANCE OF SMART ANTENNAS WITH ADAPTIVE COMBINING AT HANDSETS FOR THE cdma2000 SYSTEM

Suk Won Kim<sup>1</sup>, Dong Sam Ha<sup>1</sup>, and Jeong Ho Kim<sup>2</sup>

<sup>1</sup>VTVT (Virginia Tech VLSI for Telecommunications) Laboratory

Department of Electrical and Computer Engineering, Virginia Tech, Blacksburg, Virginia 24061 USA

<sup>2</sup>Next Generation Wireless Communication Research Laboratory

LG Electronics, Inc, Hogye-dong 533, Dongan-gu, Anyang-shi, Kyongki-do, Korea

Phone: +1-540-231-4942 Fax: +1-540-231-3362

E-mail: swkim@vt.edu, ha@vt.edu, and jhkim@lgic.co.kr

### ABSTRACT

In this paper, we present simulation results for the performance gain of smart dual antennas with adaptive combining at handsets for the forward link in the cdma2000 system. The adaptive algorithm based on the normalized least-mean-square (N-LMS) algorithm is applied, in which antenna weights are recursively obtained. The system was modeled with the SPW of Cadence. Our simulation results show that the performance gain (in terms of the reduction of the frame error rate) of a smart dual antenna system over a single antenna system lies in the range of 0.8 dB to 2.2 dB depending on the mobile velocity.

### I. INTRODUCTION

Smart antenna not only combats multipath fading, but also suppresses interference signals. When spatial signal processing achieved through smart antenna is combined with temporal signal processing, the space-time processing can repair signal impairments to result in a higher network capacity, coverage, and quality [1]-[3]. When compared with the conventional single antenna system, a smart antenna system requires additional antennas and circuitry to process multiple antenna signals. The additional antennas and circuitry result in higher cost and more power consumption.

Smart antenna techniques have been considered mostly for base stations so far [4],[5] because of high system complexity and high power consumption. Recently, smart antenna techniques have been applied to mobile stations or handsets [6]-[8]. Also, one of the third generation wireless personal communication systems, 3GPP (third generation partnership project) [9], requires antenna diversity at base stations and optionally at mobile stations [10]. Due to the compact size and stringent cost of handsets and the limited battery capacity, smart antennas at handsets should have low circuit complexity and low power dissipation. To justify employment of smart antenna techniques at handsets, the performance gain should be large enough to offset the additional cost and power consumption.

In [11], we showed that smart antennas with diversity combining scheme at handsets for the cdma2000 system

[12] improved the performance (reduction of the frame error rate) by from 1.7 dB to as high as 12.7 dB depending on the correlation of the dual antenna signals.

When an antenna array with identical antenna elements is uniformly spaced at the distance of  $\lambda/2$  (where  $\lambda$  is a carrier wavelength), the correlation between the adjacent antenna signals is high. The only difference, in practice, is the phase shift due to a non-zero angle of arrival. When the smart antenna combines each antenna signal with proper weights, it is possible to extract the desired signal and to suppress the interference signal from all received signals. When the antenna weights are dynamically updated by the adaptive algorithm, the smart antenna provides the maximum output signal to interference-plus-noise ratio (SINR).

In the forward link of the cdma2000 system, the signal transmitted from the base station is the superposition of all active users' signals and control signals (pilot, sync, and paging signals). The desired user signal and multiple access interferences (MAIs) traverse the same paths, but they are inherently orthogonal to each other. So it does not pose a serious problem. In fact, the main source of interference is coming from adjacent cells (inter-cell interference). Since the number of adjacent base stations is small, a dual antenna system is a good candidate for the handsets. It should be noted that a receiver with  $M$  antennas can suppress  $M-1$  interferences [13].

In this paper, we propose a smart dual antenna system incorporated into handsets for the cdma2000 system and present simulation results on the performance gain under the employment of adaptive combining. The adaptive combining method is based on the normalized least-mean-square (N-LMS) algorithm [14]-[16]. The cdma2000 system with smart dual antennas and the outdoor wireless channel were modeled and simulated to evaluate the performance gain using the SPW (signal processing worksystem) of Cadence.

The paper is organized as follows. The channel model employed for our simulation and the cdma2000 system are briefly described in Section 2. The adaptive algorithm to compute the antenna weights is presented in Section 3. The system setup for simulation and the simulation results are

provided in Section 4. Finally, Section 5 concludes the paper.

## II. CHANNEL MODEL AND THE cdma2000 SYSTEM

We assume that the dual antennas at a handset are identical, omnidirectional, and separated within a wavelength of the carrier. For a wireless channel model [17], three components are considered for a typical variation in the received signal level. The three components are mean path loss, lognormal fading (or slow fading), and Rayleigh fading (or fast fading). A channel model also considers spreads: i) delay spread due to multipath propagation and ii) Doppler spread due to mobile motion. We consider the spatially correlated fading channel model in this paper. Each antenna signal is assumed to have the same lognormal and Rayleigh fadings in the spatially correlated fading channel model. Thus the two signals are different only in phase due to a non-zero angle of arrival (AOA). Each multipath signal is assumed to have the same arrival time for the two antennas. The spatially correlated fading channel model is illustrated in Figure 1. The signal  $s(t)$  represents the transmitted signal from the base station in the figure, and signals  $r_1(t)$  and  $r_2(t)$  represent the two received antenna signals at the mobile station.

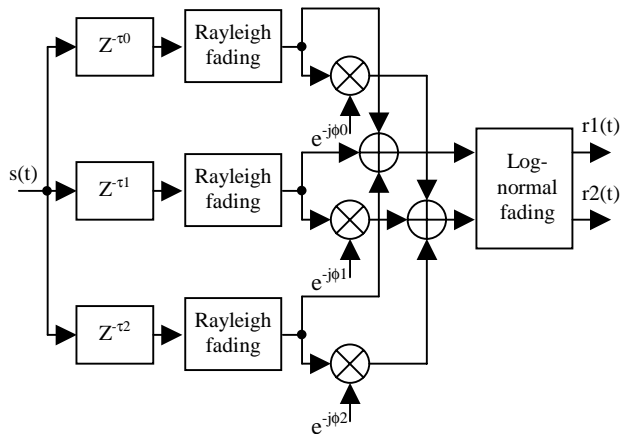

Figure 1. Spatially Correlated Fading Channel Model

The cdma2000 is a synchronous CDMA system that was proposed by TIA as a third generation standard to meet the ITU (International Telecommunication Union) IMT-2000 (International Mobile Telecommunications) requirements. A detailed description of the cdma2000 system is available in [12]. Figure 2 shows a block diagram of a typical forward link of the cdma2000 system that was considered for our simulation. One frame of user data bits is randomly generated and the generated data bits are applied to the channel coder and the spreader. The spread

data signal is added with the control signals and all the other users' signals. The added signal is quadrature modulated and applied to the shaping filter. The shaped signal is transmitted through the channel. The received signal is shaped back and a rake receiver despreads each multipath signal and combines them. The rake receiver output is applied to the channel decoder. In our simulation the decoded data bits are compared with the original data bits to evaluate the system performance. The detailed description of the block diagram is found in [11].

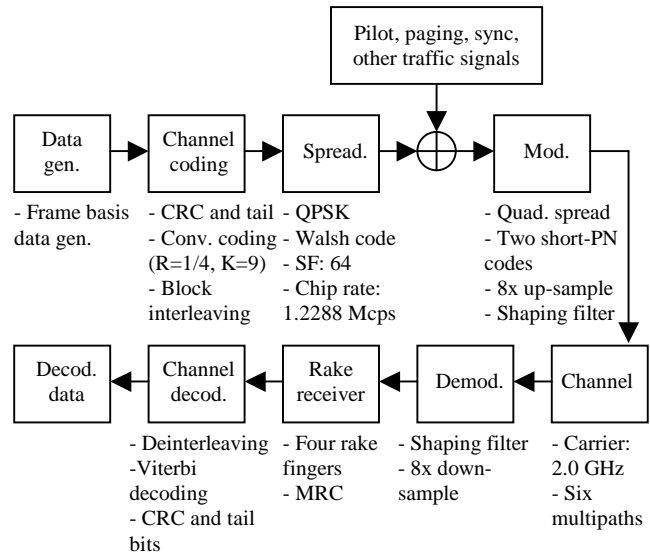

Figure 2. Forward Link of the cdma2000 System

## III. ADAPTIVE ALGORITHM

The most widely used adaptive algorithm is based on the least-mean-square (LMS) algorithm, in which antenna weights are recursively obtained to minimize the mean square error using the following equations:

$$\mathbf{w}(n+1) = \mathbf{w}(n) + \mu \mathbf{u}(n) \mathbf{e}^*(n) \text{ and } \mathbf{e}(n) = \mathbf{d}(n) - \mathbf{y}(n), \text{ and } \mathbf{y}(n) = \mathbf{w}^H(n) \mathbf{u}(n),$$

where  $\mathbf{w}(n)$  is the antenna weight,  $\mathbf{u}(n)$  is the input vector of the antenna signals, and  $\mathbf{e}(n)$  is the error signal between the desired response  $\mathbf{d}(n)$  and the weighted antenna output  $\mathbf{y}(n) = \mathbf{w}^H(n) \mathbf{u}(n)$ . The symbol  $*$  represents a complex conjugation and the symbol  $H$  represents a Hermitian operation – transposition and complex conjugation. If the step size  $\mu$  is chosen such that  $0 < \mu < 2/P$  (where  $P$  is the sum of powers of each antenna input signal), the algorithm guarantees the convergence of the antenna weights. The major benefit of the LMS algorithm is its simplicity compared to other adaptive algorithms.

The LMS algorithm, however, suffers from a gradient noise amplification problem when the input signal  $\mathbf{u}(n)$  is large, i.e., the correction term  $\mu \mathbf{u}(n) \mathbf{e}^*(n)$  is large. To

circumvent the problem, the following normalized LMS (N-LMS) algorithm is usually used:

$$\mathbf{w}(n+1) = \mathbf{w}(n) + \frac{\mu}{\|\mathbf{u}(n)\|^2} \mathbf{u}(n)\mathbf{e}^*(n),$$

where  $\mu$  is a step size in the range of  $0 < \mu < 2$ . The N-LMS algorithm exhibits a faster rate of convergence than the original LMS algorithm for both uncorrelated and correlated input data [14].

When the adaptive algorithm is applied to the wireless communication system, the circuit complexity of the adaptive algorithm is an important factor to select the algorithm. It is a particularly important factor for mobile handsets, since low complexity is highly desirable for handsets. Due to the simplicity of the algorithm, the LMS algorithm and the normalized LMS (N-LMS) algorithm are widely used for the adaptive antenna array systems [15],[16].

The adaptive combining scheme based on N-LMS algorithm is described in the following. The transmitted signal  $s(t)$  can be represented in the complex form as

$$s(t) = [\alpha_0 w_0(t) + \alpha_1 d_1(t)w_1(t) + \dots + \alpha_n d_n(t)w_n(t)] p(t),$$

where  $\alpha_k$ ,  $d_k(t)$ ,  $w_k(t)$ , and  $p(t)$  represent the link budget, each user's data signal, the Walsh code, and pseudo-noise (PN) code, respectively. The received signal  $r^{(j)}(t)$  on the  $j$ th antenna,  $j = 1$  and  $2$ , is represented as

$$r^{(j)}(t) = \sum_{m=1}^M \sqrt{2S_m} \xi_m^{(j)}(t)s(t-\tau_m) + n^{(j)}(t),$$

where  $M$  is the number of multipaths,  $S_m$  is the average received signal power associated with the  $m$ th path,  $\xi_m^{(j)}(t)$  is the complex channel gain for the  $m$ th multipath with the time delay  $\tau_m$ , and  $n^{(j)}(t)$  is the complex Gaussian noise.

The pilot signal for the  $m$ th multipath on the  $j$ th antenna is despread by

$$y^{(j)}_{0,m}(n) = \frac{1}{T} \int_{nT+\tau_m}^{(n+1)T+\tau_m} r^{(j)}(t)[p(t-\tau_m)w_0(t-\tau_m)]^* dt, \quad (1)$$

where  $T$  is the symbol period. The despread pilot signal from each antenna is weighted and combined as

$$z_{0,m}(n) = \sum_{j=1}^2 y^{(j)}_{0,m}(n)\omega_m^{(j)*}(n),$$

where  $\omega_m^{(j)}$  is the antenna weight for the  $m$ th multipath on the  $j$ th antenna. The combined pilot signal is used to coherently combine the desired user's signal, and the despread pilot signal is used to produce the reference signal. The desired  $k$ th user signal for the  $m$ th multipath on the  $j$ th antenna is despread by

$$y^{(j)}_{k,m}(n) = \frac{1}{T} \int_{nT+\tau_m}^{(n+1)T+\tau_m} r^{(j)}(t)[p(t-\tau_m)w_k(t-\tau_m)]^* dt.$$

The despread  $k$ th user signal from each antenna is weighted and combined as

$$z_{k,m}(n) = \sum_{j=1}^2 y^{(j)}_{k,m}(n)\omega_m^{(j)*}(n),$$

where  $\omega_m^{(j)}$  is the same antenna weight used for the pilot signal. Then, the user signal from each multipath is coherently combined using the pilot signal from each multipath as following:

$$z_k(n) = \sum_{m=1}^M z_{k,m}(n) z_{0,m}^*(n).$$

Using the above expression (1) the antenna weights can be computed in a recursive manner based on the N-LMS algorithm as follows.

$$\omega_m^{(j)}(n+1) = \omega_m^{(j)}(n) + \mu (y^{(j)}_{0,m}(n) / \sum_{j=1}^2 |y^{(j)}_{0,m}(n)|^2) e^*_{0,m}(n).$$

To compute the error signal  $e_{0,m}(n) = \check{z}_{0,m}(n) - z_{0,m}(n)$ , the desired reference signal  $\check{z}_{0,m}(n)$  is required. It is obtained by

$$\check{z}_{0,m}(n) = \alpha_Q \check{z}_{0,m}(n-1) + (1-\alpha_Q)(|y^{(1)}_{0,m}(n)| + |y^{(2)}_{0,m}(n)|),$$

where  $\check{z}_{0,m}(0) = (|y^{(1)}_{0,m}(0)| + |y^{(2)}_{0,m}(0)|)$  and  $\alpha_Q$  is the forgetting factor. The forgetting factor is used to define the time duration over which the pilot signals are averaged to obtain the reference signal. The initial antenna weights for each multipath are arbitrarily defined as  $[\omega_m^{(1)}(0) \ \omega_m^{(2)}(0)] = [1 \ 0]$ . The antenna weights should adapt fast enough to track the fading of the desired and interfering signals. However, the rate of the change should be much slower than the data rate.

The rake finger is a basic building block for a rake receiver, and the adaptation logic for the antenna weights is a basic building block for a smart antenna system. Logic diagrams for each building block are presented in Figure 3. The rake finger also includes the fine timing acquisition logic, but it is omitted in the figure for brevity.

#### IV. SIMULATION SETUP AND RESULTS

To validate the performance gain of the smart dual antennas at handsets under the employment of the N-LMS algorithm, the cdma2000 system with the proposed smart antenna is modeled and simulated with the SPW tool.

A signal from the base station propagates through the channel. The signal received at a handset antenna is applied to its own demodulator and then to each rake finger. In a single antenna system, each rake finger output is coherently combined. In a dual antenna system with the adaptive combining scheme, each rake finger signal from each antenna is combined with the adaptively computed antenna weights. Then the output of each adaptive combiner (AC) is coherently combined. The dual antenna system with adaptive combining scheme is shown in Figure 4, in which the AC contains the adaptation logic to compute antenna

weights and a combiner of each weighted rake finger output.

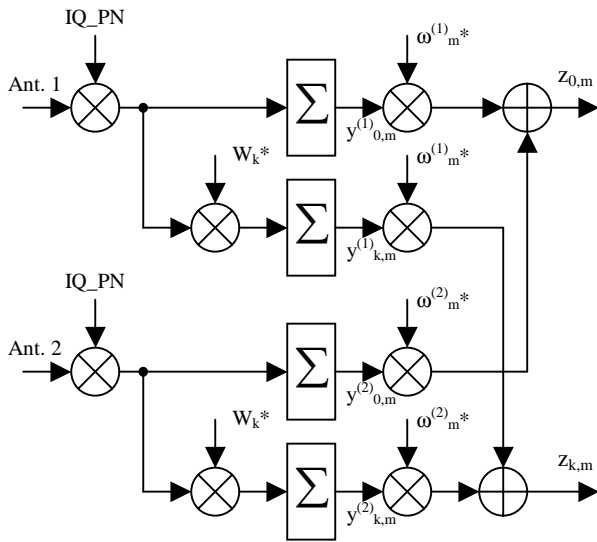

(a) Rake Finger for the  $m$ -th Multipath

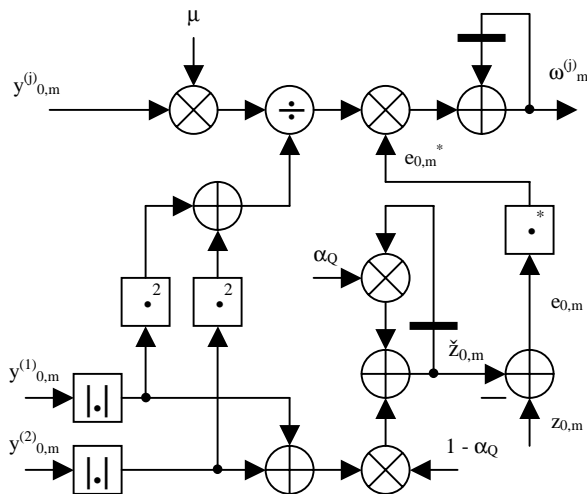

(b) Adaptation Logic for Antenna Weights

Figure 3. Building Blocks of an Adaptive Rake Receiver for Smart Antennas

We considered the following environment; the distance from the base station to the mobile station is 1000 m, and the standard deviation of the path loss in the lognormal fading is 10 dB, which is a typical value for outdoor channel. In simulating the system with the SPW of Cadence, we used the link budget shown in Table 1. From Table 1, only 2.5% (or 0.74 W) of the total transmitted power of 30 W is allocated to the desired user traffic channel. To shorten the simulation time, a simplified simulation model was used in our simulation. The number

of multipath signals was limited to two in the channel model. Consequently, a rake receiver with two rake fingers for each antenna was used to despread and combine the multipath signals. For simplicity, two multipath signals were assumed to have, on average, the same level of the received signal power. One multipath signal is effectively an interference signal to the other multipath signal. AWGN is also added to the channel, and it results in 9.79 dB of SINR. The two factors that affect the performance of the N-LMS algorithm are the step size and the forgetting factor. The step size,  $\mu = 0.125$ , and the two forgetting factors,  $\alpha_Q = 0.975$  and  $0.9875$  (which are the cases where the reference signal is obtained by averaging the pilot signal over the 40 and 80 symbol durations, respectively) were chosen through trial and error. The 40 and 80 symbol durations correspond to 2.08 ms and 4.17 ms in the real operation, respectively.

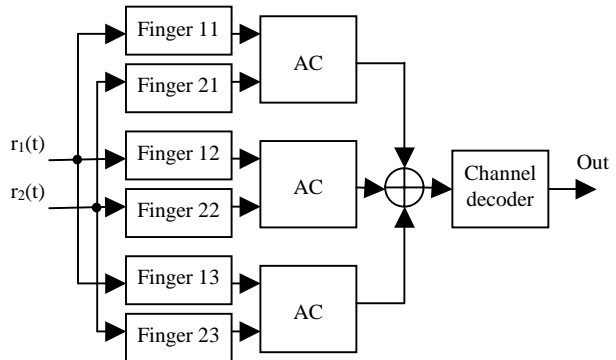

Figure 4. Rake Receiver for Dual Antenna System with Adaptive Combining

Table 1. Link Budget

| Channel       | Power (W) |
|---------------|-----------|
| Pilot         | 5.99      |
| Paging        | 1.89      |
| Sync          | 0.75      |
| User traffic  | 0.74      |
| Power control | 0.13      |
| Other users   | 20.50     |
| Total         | 30.00     |

The simulation was performed for 3999 frames in which the period of each frame is 20 ms. Hence, it covers 80 seconds in the real operation. To evaluate the system performance, the frame error rate (FER) was used as the performance metric. We performed simulation on a Sun UltraSPARC10 workstation with 1 GB of main memory. The CPU time was not measured, but the elapsed time for the simulation is about five days for each simulation run. We performed the simulation three times for each mobile velocity and each angle of arrival. Then the three

simulation results are averaged. The simulation results with different mobile velocity and different angle of arrival are summarized in Table 2. Three different mobile velocities, 100 km/h, 50 km/h, and 25 km/h, were considered, and the Doppler frequencies for the three mobile velocities are 185 Hz, 93 Hz, and 46 Hz under 2.0 GHz of carrier frequency. Two sets of the angle of arrival were arbitrarily chosen: set 1 (AOA<sub>1</sub>) with 20° for multipath 1 and 45° for multipath 2 and set 2 (AOA<sub>2</sub>) with -45° for multipath 1 and 35° for multipath 2. The first two rows in the table represent the performance of a single antenna. The remaining two rows represent the performance of the dual antennas with the two different forgetting factors. The top element of each entry is the number of erroneous frames out of 3999 frames simulated, and the bottom element is the percentile.

Table 2. Frame Error Rate of Smart Dual Antennas

|           |                     | 100 km/h         | 50 km/h          |                  | 25 km/h          |
|-----------|---------------------|------------------|------------------|------------------|------------------|
|           |                     | AOA <sub>1</sub> | AOA <sub>1</sub> | AOA <sub>2</sub> | AOA <sub>1</sub> |
| Antenna 1 |                     | 588.7<br>14.7%   | 605.3<br>15.1%   | 590.0<br>14.8%   | 600.0<br>15.0%   |
| Antenna 2 |                     | 585.7<br>14.7%   | 598.0<br>15.0%   | 573.0<br>14.3%   | 601.0<br>15.0%   |
| AC        | $\alpha_Q = 0.975$  | 488.0<br>12.2%   | 399.3<br>10.0%   | 428.0<br>10.7%   | 360.0<br>9.0%    |
|           | $\alpha_Q = 0.9875$ | 520.7<br>13.0%   | 435.3<br>10.9%   | 473.3<br>11.8%   | 381.0<br>9.5%    |

When a single antenna is employed, the FERs are around 15% for all the three mobile velocities. When dual antennas are employed, the FERs are reduced in the range of 1.7% (which is from 14.7% to 13.0% for 100 km/h of the mobile velocity) to 6.0% (which is from 15.0% to 9.0% for 25 km/h of the mobile velocity). The forgetting factor  $\alpha_Q = 0.975$  performs better than  $\alpha_Q = 0.9875$  for the dual antenna system for all the three velocities. The reduction ratio of the FER for the dual antenna system under  $\alpha_Q = 0.975$  over the better performing single antenna system is 0.8 dB (equivalently reduction from 14.7% to 12.2%) for 100 km/h of the mobile velocity. The reduction ratio increases to 1.8 dB (equivalently from 15.0% to 10.0%) for 50 km/h of the mobile velocity under the AOA<sub>1</sub> and 1.3 dB (equivalently from 14.3% to 10.7%) under the AOA<sub>2</sub>. The reduction ratio further increases to 2.2 dB (equivalently from 15.0% to 9.0%) for 25 km/h of the mobile velocity. In summary, i) as the mobile velocity decreases, the frame error rate of the dual antennas with adaptive combining also decreases, and ii) the adaptive algorithm with the forgetting factor  $\alpha_Q = 0.975$  performs better than that for the forgetting factor  $\alpha_Q = 0.9875$ . In conclusion, a smart dual antenna system with adaptive combining scheme at handsets is beneficial for the cdma2000 system.

## V. CONCLUSION

In this paper, we presented simulation results for the performance gain of smart dual antennas with adaptive combining at handsets for the forward link in the cdma2000 system. The SPW of Cadence was used to model the system and to evaluate the performance. The adaptive algorithm based on the normalized least-mean-square (N-LMS) algorithm is applied, in which antenna weights are recursively obtained to minimize the mean square error. Our simulation results indicate that

- i) a dual antenna system with adaptive combining reduces the FER by in the range of 0.8 dB to 2.2 dB over a single antenna system depending on the mobile velocity,
- ii) as the mobile velocity decreases, the dual antennas system with adaptive combining further reduces the frame errors, and
- iii) the adaptive algorithm with the forgetting factor  $\alpha_Q = 0.975$  performs better than that for the forgetting factor  $\alpha_Q = 0.9875$ .

In conclusion, smart dual antennas with adaptive combining at handsets are beneficial for the cdma2000 system. The algorithm parameters such as the forgetting factor and the step size are sensitive to the performance of smart antennas at handsets, and further study in the area is necessary.

## REFERENCES

- [1] A. J. Paulraj and B. C. Ng, "Space-Time Modems for Wireless Personal Communications," *IEEE Personal Communications*, pp. 36-48, February 1998.
- [2] R. Kohno, "Spatial and Temporal Communication Theory Using Adaptive Antenna Array," *IEEE Personal Communications*, pp. 28-35, February 1998.
- [3] J. H. Winters, "Smart Antennas for Wireless Systems," *IEEE Personal Communications*, pp. 23-27, February 1998.
- [4] J. S. Thompson, P. M. Grant, and B. Mulgrew, "Smart Antenna Arrays for CDMA Systems," *IEEE Personal Communications*, pp. 16-25, October 1996.
- [5] S. Affes and P. Mermelstein, "A New Receiver Structure for Asynchronous CDMA: STAR – The Spatio-Temporal Array-Receiver," *IEEE Journal on Selected Areas in Communications*, Vol. 16, No. 8, pp. 1411-1422, October 1998.
- [6] [http://www.qualcomm.com/hdr/pdfs/HDR\\_Tech\\_Airlink.pdf](http://www.qualcomm.com/hdr/pdfs/HDR_Tech_Airlink.pdf), "1x High Data Rate (1xHDR) Airlink Overview," April 2000.
- [7] G. Dolmans and L. Leyten, "Performance Study of an Adaptive Dual Antenna Handset for Indoor Communications," *IEE Proceedings of Microwaves, Antennas and Propagation*, Vol. 146, No. 2, pp. 138-1444, April 1999.

- [8] P. B. Wong and D. C. Cox, "Low-Complexity Cochannel Interference Cancellation and Macroscopic Diversity for High-Capacity," *IEEE Transactions on Vehicular Technology*, Vol. 47, No. 1, pp. 124-132, February 1998.
- [9] <http://www.3gpp.org/>.
- [10] [http://www.3gpp.org/ftp/Specs/December\\_99/25\\_series/25101-310.zip](http://www.3gpp.org/ftp/Specs/December_99/25_series/25101-310.zip), "TS 25.101 UE Radio Transmission and Reception (FDD)," December 1999.
- [11] S. W. Kim, D. S. Ha, and J. H. Kim, "Performance Gain of Smart Dual Antennas at Handsets in 3G CDMA System," CDMA International Conference, Vol. 2, pp. 223-227, November 2000.
- [12] [http://www.cdg.org/frame\\_3giis.html](http://www.cdg.org/frame_3giis.html), "Wideband cdmaOne (TIA cdma2000) Radio Transmission Technology Proposal," International Telecommunication Union, Radiocommunication Study Groups, June 1998.
- [13] J. Salz and J. H. Winters, "Effect of Fading Correlation of Adaptive Arrays in Digital Mobile Radio," *IEEE Transactions on Vehicular Technology*, pp. 1049-1057, November 1994.
- [14] S. Haykin, *Adaptive Filter Theory*, Prentice Hall, New Jersey, 1996.
- [15] S. Tanaka, A. Harada, M. Sawahashi, and F. Adachi, "Experiments on Coherent Adaptive Antenna Array Diversity for Wideband DS-CDMA Mobile Radio," *IEEE Journal of Selected Areas in Communications*, Vol. 18, No. 8, pp. 1495-1504, August 2000.
- [16] S. Tanaka, M. Sawahashi, and F. Adachi, "Pilot Symbol-Assisted Decision-Directed Coherent Adaptive Array Diversity for DS-CDMA Mobile Radio Reverse Link," *IEICE Transactions on Fundamentals*, Vol. E80-A, No. 12, pp. 2445-2454, December 1997.
- [17] T. S. Rappaport, *Wireless Communications: Principles and Practice*, Prentice Hall, New Jersey, 1996.